

When it comes to conveying ash, only the highest quality chain and components are acceptable. PTS Industrial offers chain and components that meet the demanding requirements of the coal mining industry. This chain is manufactured on the latest state of the art machinery and then calibrated to a tolerance of not more than .05 mm variance over any 5 link section.

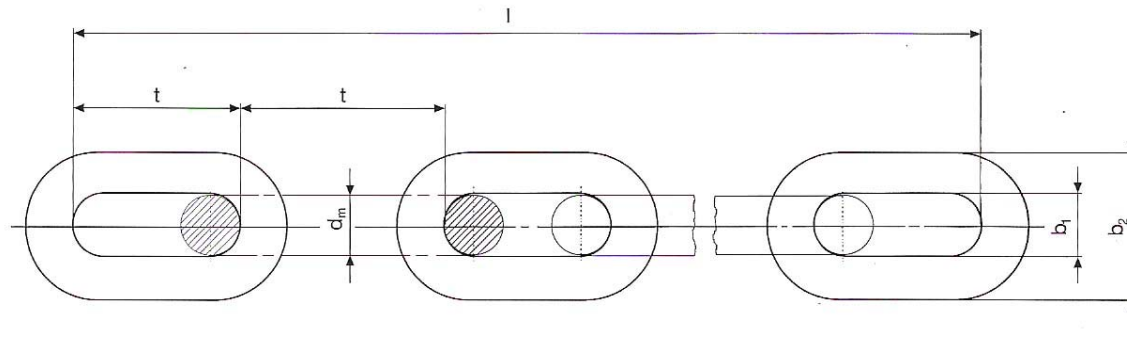

Chain Size d x p	Load Test (lbs.)	Load Break (lbs.)	Elongation Test Min. %	Elongation Test Max. %	Total Weight (lbs./ft.)
14 x 50	44960	56200	1.6	14	2.69
18 x 64	74184	92168	1.6	14	4.44
19 x 64.5	88928	101160	1.6	14	5.11
22 x 86	110152	137128	1.6	14	6.39
24 x 86	130384	161856	1.6	14	7.80
26 x 92	191080	254024	1.6	14	9.21
30 x 108	242784	325960	1.6	14	12.10
34 x 126	303480	404640	1.6	14	15.26

OTHER CHAIN SIZES AVAILABLE UPON REQUEST CONTACT PTS INDUSTRIAL: quote@ptsindustrial.com